

FEATURES AND BENEFITS

- Australian design and manufacture
- Fully automated screening capture
- Robust
- Low maintenance and long service life
- High capture rate
- Corrosion resistant

APPLICATIONS

- Water treatment plants
- Wastewater treatment plants
- Abattoirs
- Pulp and paper mills
- Tanneries
- Seaweed farms
- Water canals and catchments

PRODUCTS AND SERVICES

Aquatec Maxcon has over 47 years of experience in treating water and wastewater for both municipal and industrial applications.

From inception, Aquatec Maxcon has sought to develop high quality market leading technologies better suited to the relatively severe Australian conditions. We have spent over 23 million dollars on research and development of designs that have been refined using input from our workshop, field installation crews and operations staff to ensure the production of reliable and robust equipment. Together with leading technologies sourced internationally, this has now become the most comprehensive range of water and wastewater technology available in Australia.

Aquatec Maxcon Pty Ltd is part of the Aquatec Maxcon Group which provides a vertically integrated range of in-house services including:

- Design and construction
- Pilot plant and treatability studies
- Process selection and equipment design
- Project management
- Complete in-house manufacturing
- Machine and plant automation
- System integration and SCADA configuration
- Installation, commissioning and operations maintenance

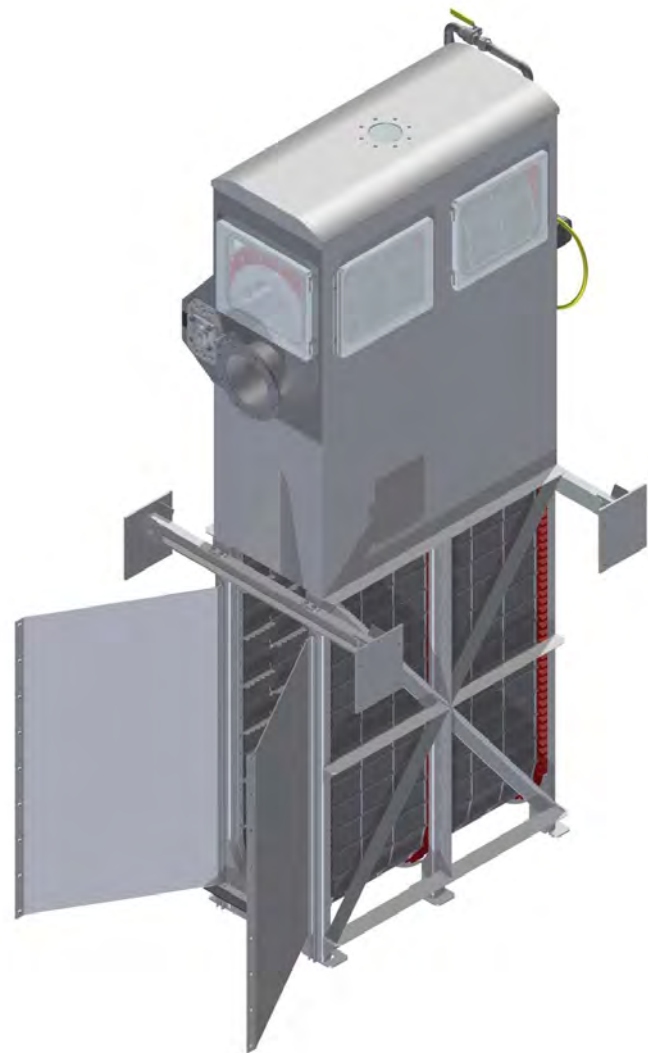

UH650-2-60 3D Model





UH650-2-60 Assembly

AQUA BAND SCREEN SCREENING REMOVAL SYSTEM

- EXCEPTIONAL CAPTURE RATE
- PREMIUM ENGINEERED PLASTICS TO OUTLAST OTHER SCREENS IN HARSH GRIT APPLICATIONS
- NO INTERNAL DRIVE SHAFTS, NO SUBMERGED BEARINGS OR FASTENERS AND NO BRUSHES



 Brisbane
Head Office and Factory
119 Toongarra Road
Ipswich QLD 4305
P: +61 (0) 7 3813 7100
F: +61 (0) 7 3813 7199

 Sydney
Office and Factory
8 Charles Street
St Marys NSW 2760
P: +61 (0) 2 8603 5200
F: +61 (0) 2 8603 5299

 Melbourne
Office and Factory
6/64 Oakover Road
Preston VIC 3072
P: +61 (0) 3 9480 8000
F: +61 (0) 3 9480 8099

AQUA BAND SCREEN

The AQUA BAND screen offers an efficient method of filtering and removal of unwanted solids designed specifically for primary wastewater inlet treatment.

The thick plastic perforated panels provide two-dimensional screening from 2mm to 20mm diameter holes. This allows the band screen to achieve a very high screenings capture rate as compared with other mechanical screening types. The extra thick panels prevent 'hairpinning' of the screenings.

Inlet flows enter into the centre of the band screen and exits through both sides and the bottom of the screen. This means that the perforated filter panels are not in the direct line of hydraulic force created by the inlet flows. This greatly increases the total panel surface area and helps prevent impact damage as well as 'pull through' of the screenings.

The band screen belt is comprised of high quality, chemical resistant perforated panels, 316 S/S lifters (to collect large solids), and 316 S/S axles. The belt is driven externally by a series of very high wear resistant engineered plastic links which form a geared rack along the vertical side of the band screen. This means there are no internal or submerged shafts which invite the collection of rags or screenings.

The Aqua Band screen is fabricated and assembled entirely in Australia and supports local Australian business.

AQUATEC MAXCON



UH650-1-50

BUILT TO LAST

As a market leader in the sewage and industrial wastewater industry, Aquatec Maxcon understands the demands and harsh conditions that screening equipment is regularly subject to. From corrosive atmospheres to obscure objects, the Aqua Band screen is made to survive it all.

- The plastic used for the running links is premium engineered plastic which has three times the strength compared with UHMWPE (the choice of almost all other band screen manufacturers) and 1.6 times higher hardness. This allows the Aqua Band to withstand much higher stresses and to operate in very high grit applications.
- Stainless Steel drive shaft support bearings for a long service life.
- Side mounted drive reduces wear on gear links and running faces and positions the drive at an ergonomic position for maintenance.
- Solid frame from top to bottom provides strength and rigidity during installation, removal and operation.

DESIGNED FOR MAINTENANCE

During the continued development of our products we have had many opportunities to interact and receive feedback from end user operators and our own service crew. Knowing the unique challenges associated with site installation and maintenance work has helped us tailor our design towards simplicity and low maintenance.

- Our unique design allows individual panels to be removed and replaced without dismantling the belt or removing any other components.
- Transparent inspection hatches on all four sides to allow operators to easily see inside the band screen while it is operating, without the risk of making contact with hazardous material or moving parts.

- No support fasteners underneath the platform level allows the entire band screen to be installed and removed without the need of draining or accessing the channel.
- No internal or submerged drive shafts.
- No submerged roller bearings.
- No brushes required.
- Captive nuts allow for fasteners to be removed externally without risk of dropping nuts/washers into the channel.
- Wide range of available spray nozzles are easily changed and cleaned with no tools required and fully customisable to suit site conditions.
- Fabricated and assembled in Australia.



TYPICAL OPERATION

Under normal operating conditions, the screen will remain stationary in the channel while solids are captured by the panels and screened water flows on. After time the solids will accumulate against the panels, such that the panels become 'matted up' and the upstream water level rises due to additional head losses. When the level reaches a pre-determined set-point, or when the upstream/downstream level differential is measured to be above a certain range (typically 100-400mm), the screen will begin rotating. The matted panels will be raised to the top where spray nozzles clean the panels and release the screenings into a collection trough. Clean panels then become submerged in the channel to continue capturing solids in the inlet flows. The band screen can also be run in continuous mode where the screen rotates continuously, collecting and depositing captured solids.

The Aqua Band screen is designed to couple with our Aquamax Washpress which provides screening dewatering and compaction where dry screenings discharge is required.



TECHNICAL DATA

Model	Typical Flow Capacity (at 1.5m depth, 30% blinded)*	Maximum Spray Water Requirement (at 400kPa)**	Minimum Channel Width
UH650-1-50	600 L/s	2.8 L/s	0.8 m
UH850-1-50	750 L/s	3.6 L/s	1 m
UH650-2-60	1200 L/s	5.6 L/s	1.2 m
UH850-2-60	1600 L/s	7.3 L/s	1.2 m

*Flow capacity is provided for indicative purposes only. The actual capacity is dependent on the channel dimensions and top water level. Aquatec Maxcon can provide custom solutions for most channel sizes and flow requirements.

** The Aqua-Band screen can operate effectively within a pressure range of 300kPa to 700 kPa. The actual flow requirement will be dependent on the pressure available.

